

MTWB

Customized Bearings



Truck Separation Bearing

Mighty Way Industrial Limited

香港威鸿实业 有限公司

Room 13-15, 19/F, Nan Fung Centre
264-298 Castle Peak Road, Tsuen Wan, N.T., Hong Kong

Mobile: +86 13681771041

Email: sales@mtwbearing.com
13681771041@163.com



Contents

01

Introduction to Separable Bearings

02

Introduction of Product Design Features

03

R&D improvement process

04

Test Report

01

Introduction to Separable Bearings



陕西重型汽车有限公司
SHAANXI HEAVY DUTY AUTOMOBILE CO.,LTD



The separable bearing is the core component of the clutch system in heavy-duty trucks.

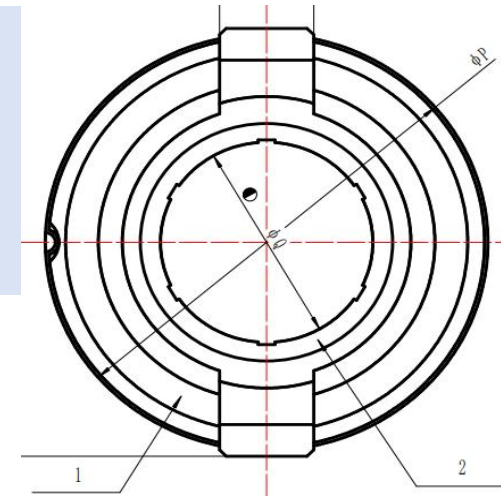

Compact structure, suitable for clutch systems with limited space, suitable for heavy-duty trucks.

Introduction of Product Design Features



Bearing body: high-precision spherical bearing, ensuring low friction and high-speed operation.

Sealed structure: dustproof, waterproof, and oil leakage resistant design, extending service life.

Adopting double-layer sealing, the sealing plate uses F rubber, and the grease is selected from Krupp high-temperature grease to enhance high temperature resistance and wear resistance.



The opposite component here is formed by grinding and processing.

Advantages: High precision, small size tolerance range.

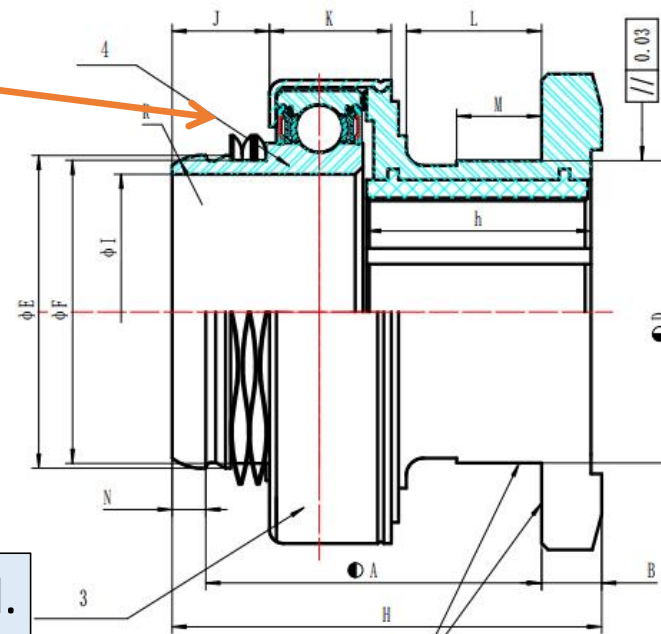

Use Krupp B L P 7 2-1 2 bearing grease instead. High performance synthetic grease designed for heavy-duty, high-temperature, and high-speed rolling bearings.



The existing sealing mechanism for the clutch release bearing of heavy-duty trucks is a single-layer structure with average sealing performance. After a period of use, the lubricating oil will leak, affecting its use. Our company offers a dual sealing structure that greatly improves sealing performance and has obtained patent certification.

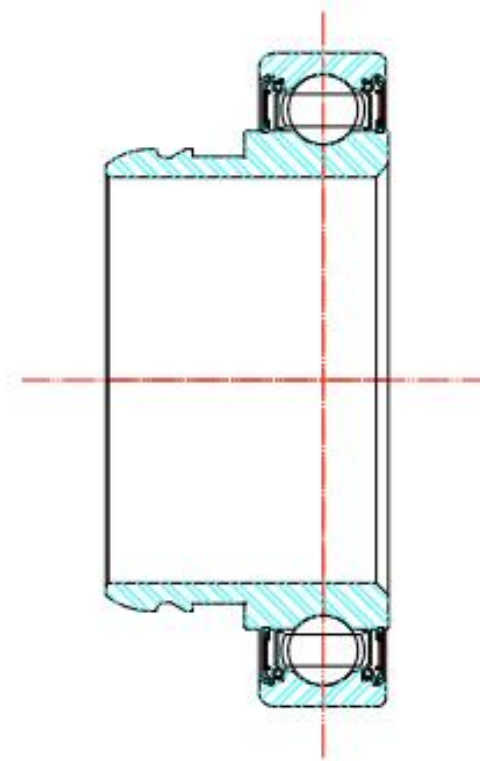



Before improvement, use a single-layer iron sealing ring.

After improvement, double-sided double sealing rings are used, and an additional layer of F rubber sheet sealing ring is added on top of the iron sealing ring.

Advantages: The dustproof, waterproof, and oil leakage prevention levels have been increased, mainly reducing oil leakage.

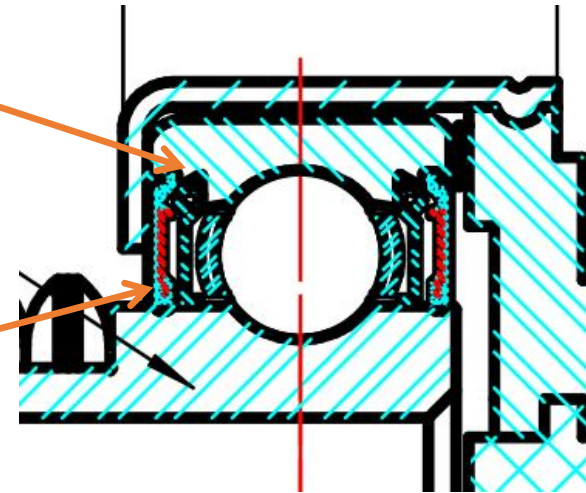

**Customer Requirement:**

1. Cover assembly speed: 1500 r/min
2. Separation stroke: 12mm
3. Frequency: 1Hz~2Hz
4. Test temperature: 150 ± 5 °C
5. Standard block thickness: 10 ± 0.02 mm
6. Test frequency: 2 million times.
7. Matching cover assembly: The maximum separation force of the FD430L-1601100GR-03 cover assembly is 7854.6N.

Actual Results:

1. Cover assembly speed: 1500 r/min
2. Separation stroke: 12mm
3. Frequency: 2Hz
4. Test temperature: 150 °C
5. Standard block thickness: 10mm
6. Test frequency: 2 million times.
7. Matching cover assembly: The maximum separation force of the FD430L-1601100GR-03 cover assembly is 7854.6N.



After 2 million bench simulation life tests at 150 °C (The maximum temperature of the bearing is 148°C), the bearing's rotational resistance increased and the bearing did not leak oil, so it can still be used.

